

T040

Lubrificatore / Lubricator



CODICI DEI PRODOTTI STANDARD A MAGAZZINO - STANDARD PRODUCTS AVAILABLE IN STOCK

Codice Code	Misura Size	Filetto Thread	Portata Flow Rate	Carico Olio Oil Load
T040103000100	LUB 1	1/4	2600 NI/min	M
T040104000100	LUB 1	3/8	2600 NI/min	M
T040104000200	LUB 1	3/8	2600 NI/min	A
T040204000100	LUB 2	3/8	5600 NI/min	M
T040205000100	LUB 2	1/2	5600 NI/min	M
T040205000200	LUB 2	1/2	5600 NI/min	A
T040307000100	LUB 3	3/4	8200 NI/min	M
T040309000100	LUB 3	1"	8200 NI/min	M
T040309000200	LUB 3	1"	8200 NI/min	A
T040309000300	LUB 3	1"	8200 NI/min	M2L

M: Manuale Manual
M2L: Manuale con sensore a due livelli Two steps sensor Manual
A: Automatico a Depressione Automatic to Vacuum-operated

Tabella dei codici di ordinazione - Article codes to be used for ordering

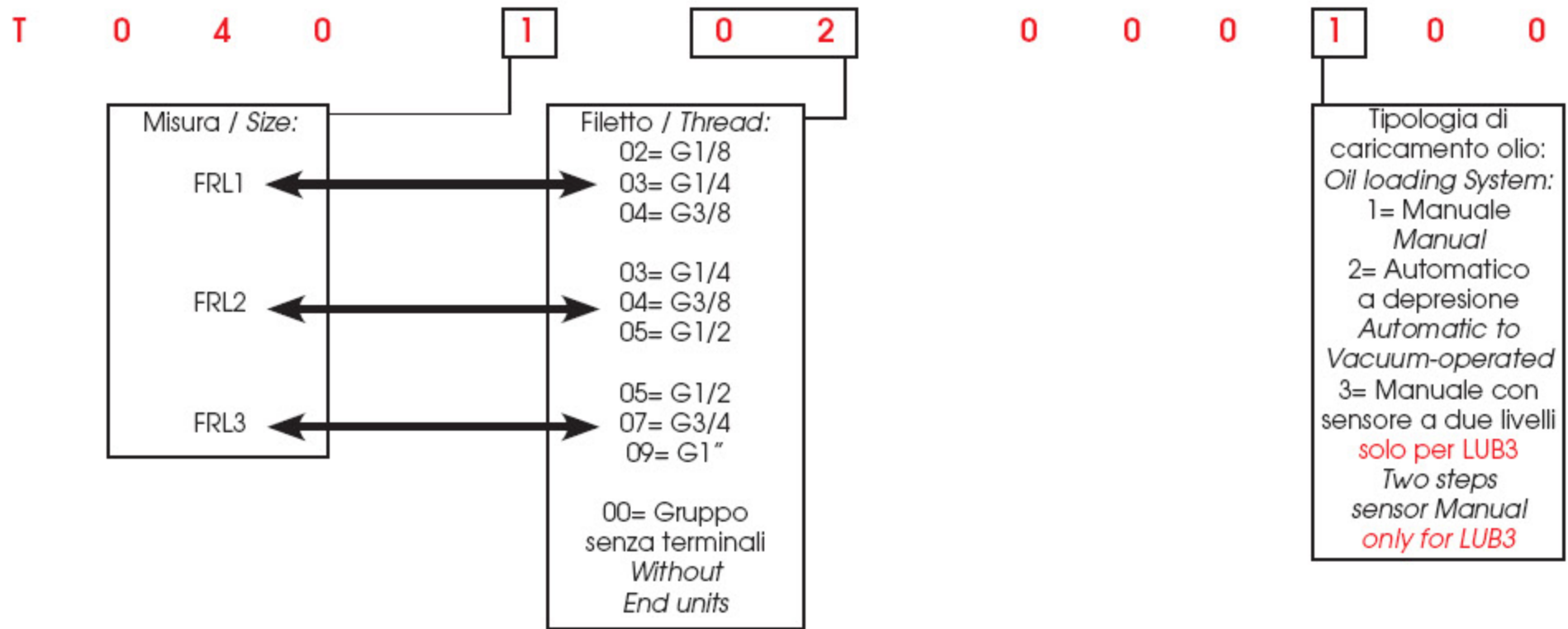

Dimensioni - Dimensions

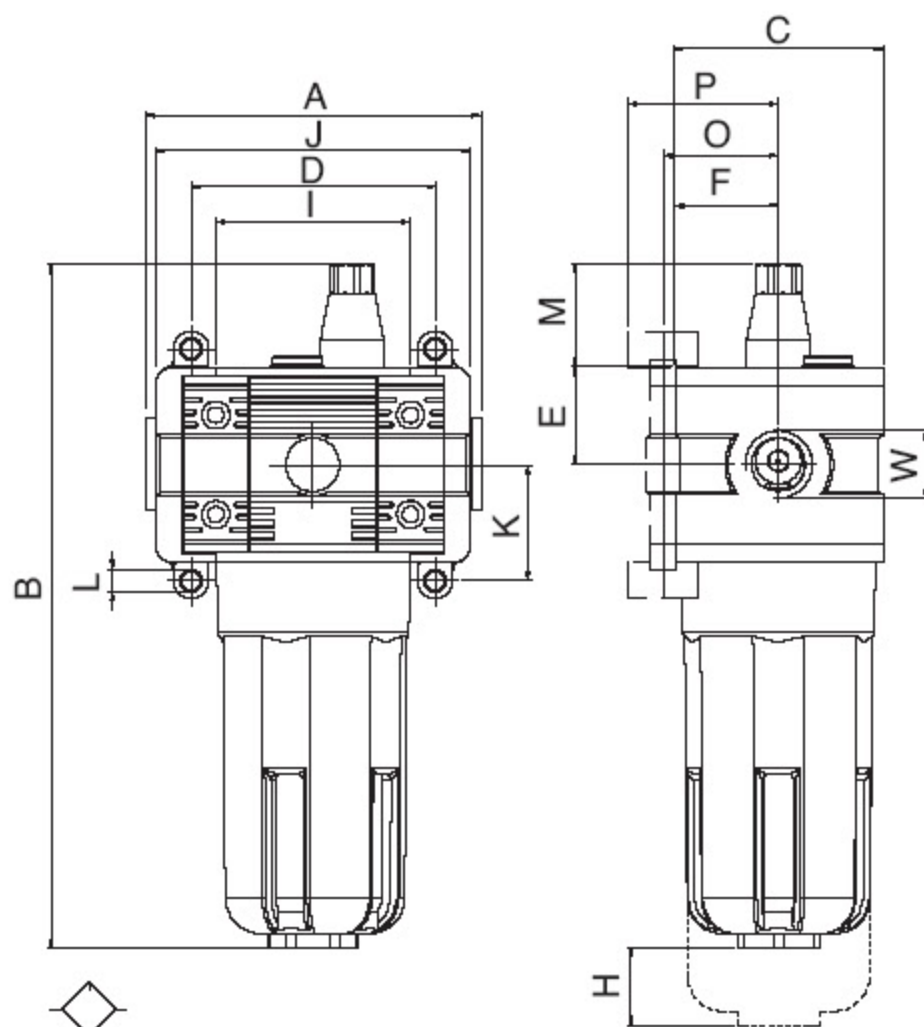

	FRL 1	FRL 2	FRL 3
A	72	89	100
B	162	195	214
C	45	59	70
D	75.5	89	106 106 111
W	1/8" - 1/4" - 3/8"	1/4" - 3/8" - 1/2"	1/2" - 3/4" - 1"
E	21	27.5	32.5
F	22.5	28.5	35
H	39	48	50
I	43	55	65
J	48.5	69	79
K	26	32.5	38
L	Ø X M4	Ø X M5	Ø X M6
M	29	29	29
O	26	32	38.5
P	32.5	38.5	45